



Half-Moon Table Cover Measure Form

CUSTOMER NAME: _____
 ADDRESS: _____
 CITY: _____ PROV/STATE: _____ POSTAL/ZIP CODE: _____
 BUSINESS PHONE: _____ CELL PHONE: _____
 EMAIL: _____



1. Place an X by each table and or leg style.
2. Fill out the corresponding measurements.
3. Fax form with your purchase order.

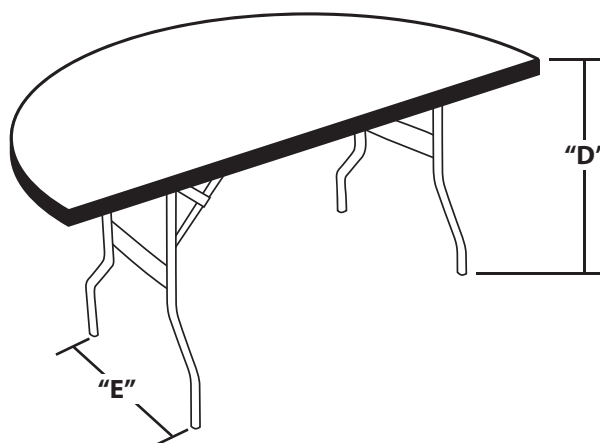
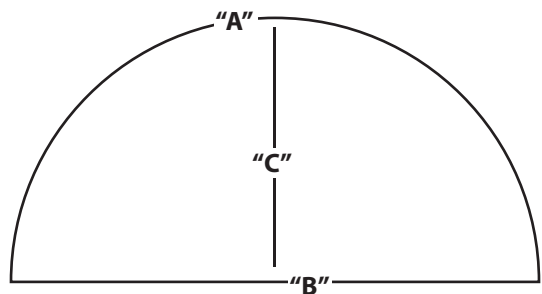

"A" - Outside Curve	
"B" - Length	
"C" - Centre Width	
"D" - Height	
"E" - Leg Span Width	
"F" - Leg Span Length	
"G" - Leg Span Length	

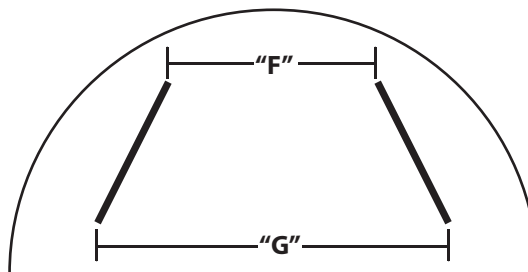

(Leg Positions)

LEG CONFIGURATION

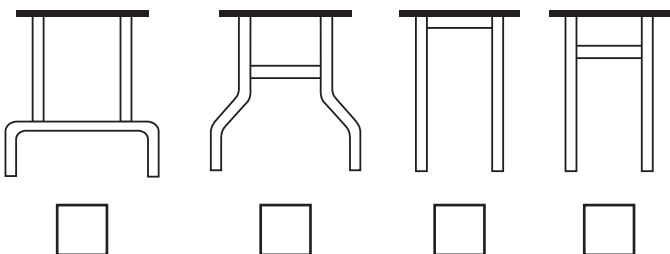

LEG POSITIONS

